



Hachoirs

TX98



Carter monobloc compact
Capot de sécurité
Entièrement Inox 10-18

Dadaux
TECHNOLOGIES



TX98



HACHOIR TX98

- Entièrement inox 18-10: carter - corps - hélice - écrou, etc.
- Carter monobloc. Démontage du corps par simple déverrouillage de la poignée latérale.
- Réducteur à bain de graisse (graissé à vie).
- Machine équipée d'un capot de protection de sortie asservi par un contact de sécurité.
- Alimentation triphasée 220/380 V 50/60 HZ
- Option monophasée 220 V.

Meat mincer - TX98

- Entirely 18-10 stainless steel (crank case, body, screw...).
- Monobloc crank case.
- Dismantling of body just by unlocking of the side handle.
- Oil bath speed reducer (permently oiled).
- Machine equipped with a protective housing leads by a safety contact.
- 3 phases, 220V/380V, 50/60Hz.

Option: Single phase motor 220V

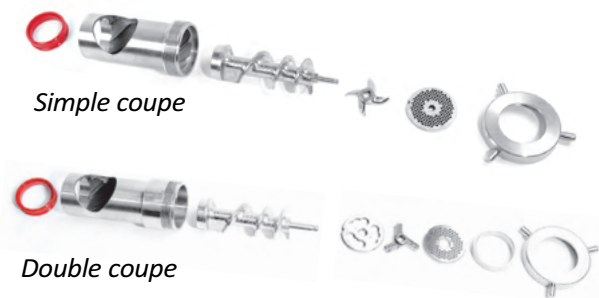

Simple coupe

Double coupe

Corps et hélice bien travaillés pour un hachage parfait TX98 double coupe système Unger

Body and propeller well protiled to have a perfect mincing

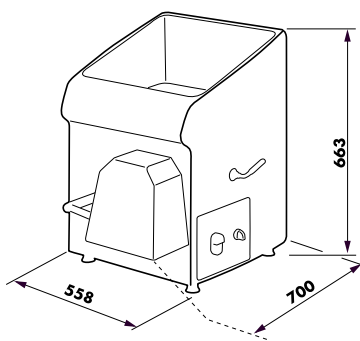

Dimensions TX98

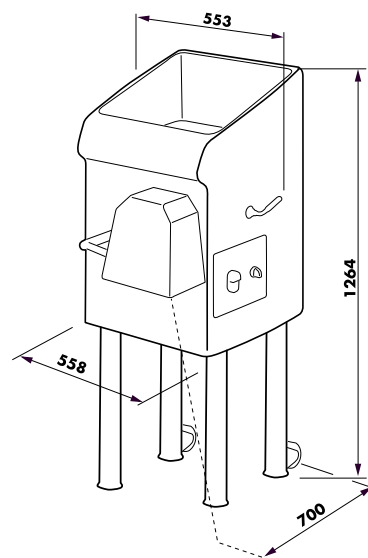

Dimensions TX98 sur socle

Réf Ref	Tension Tension	Moteur Motor	Débit théorique Theoretical debit	Capacité trémie Hopper capacity	Ø de sortie Ø Exit	Ø grille Ø Grate	Poids net Weight
TX 98	TRI, 400V, 50 HZ	3CV (2,2 Kw)	500 Kg/h	15L	98 mm	Ø 5 mm	70 Kg



Dadaux S.A.S. - Le Bouchaud - 39800 Bersaillin
 Tél. + 33 (0) 3 84 85 51 71 - Fax: + 33 (0) 3 84 85 53 92
 www.dadaux.com - E-mail: dadaux@dadaux.com