

LINE:	MEAT GRINDERS
MODEL:	MI32

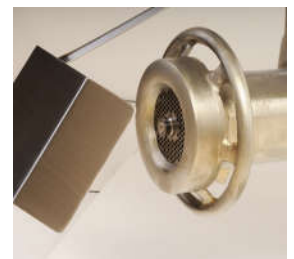

- High grinding capacity
(More than 100 kg/200 lb per hour first ground)
- Power and Productivity
- Stainless steel construction
- 3 or 5 HP motor
- Easy to clean
- Expedites customer service
- High capacity head design and deep pan
- Thermomagnetic contactor protects the motor against overloads

MINIMUM MAINTENANCE



Powerful oil bathed steel gears transmission, with no belts or pulleys to maintain

HYGIENIC



High grade stainless steel cabinet and tray, very resistant and easy to clean allow a hygienic operation and a professional presentation

Model	MI32 3HP	MI32 3HP	MI32 5HP
*Motor	3 HP / 2.23 KW Single phase	3 HP / 2.23 KW three phase	5 HP / 3.72 KW three phase
Volts	220/440 V	220/440 V	220/440 V
** Grinding capacity (3/8) First Ground	25 kg/min 55 lb/min	25 kg/min 55 lb/min	29 kg/min 64 lb/min
** Grinding capacity (1/8) Second Ground	13 kg/min 29 lb/min	13 kg/min 29 lb/min	14 kg/min 31 lb/min
Net weight	106 kg/233 lb	106 kg/233 lb	131 kg/288 lb
Shipping weight	122 kg/268 lb	122 kg/268 lb	159 kg/350 lb
Leveling feet	Yes	Yes	Yes

*Motor available 110volts/60 Hz or 220 Volts/50 Hz optional
** 35° F / 2° C Fresh Meat, lab conditions

These meat grinders are the ideal solution to handle high volume production. They feature a great production capacity.

LARGE CAPACITY AND SAFETY OPERATION

The MI32 3HP and 5HP are equipped with a safety protector guard in the feeding area. However the stomper must always be used.

LONG LASTING LIFE

The powerful oil bathed steel gears transmission (with no belts or pulleys to maintain) guarantees a long lasting life, with minimum noise and low maintenance cost.



DEFLECTOR ON THE HEAD

To avoid product's spatter that could exist due to air pockets in this powerful equipment.



HIGH VOLUME CAPACITY

Its high capacity head holds bigger pieces in to the grinding system, avoiding down time in cutting into smaller pieces.

Includes Knife, 3/16 plate and stomper



EASY TO CLEAN

Its practical grinding system and the feed pan can be completely disassembled in a few minutes without the use of tools reducing time spent on cleaning and maintenance operations.

Grinding system components are strong cast iron parts, with dip tin plating for hygiene and corrosion resistance.

DIMENSIONS

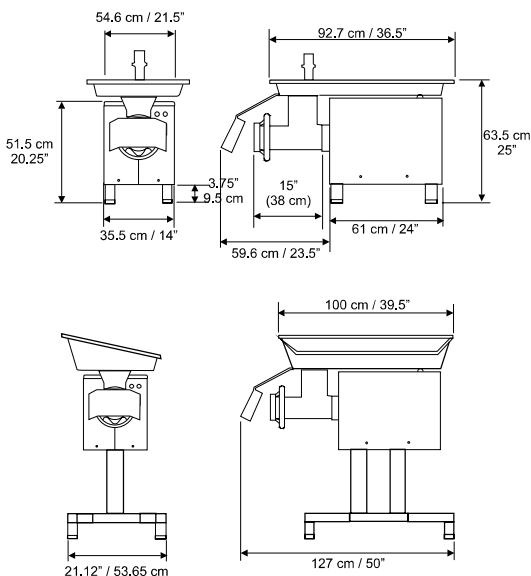

*Apply only in equipment ordered under this spec



Safety & Sanitation
Conforms UL std 763



Sanitation
Conforms NSF-8



CANADA
Conforms CAN/CSA STD C22.2



NELLA®

Est. 1901

0800 028 1105
www.nellacut.com