





INTENERITRICE *Swedlinghaus*^{dal 1950}[®]



-  *Meat tenderizer*
-  *Attendrisseur de viande*
-  *Fleisch-mürber*
-  *Tiernizadora de carnes*

INT

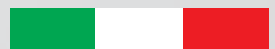



INTENERITRICE

mod. INT

Strumento professionale usato nelle macellerie, ristoranti e grandi cucine. Grazie ad un sistema di coltelli incisori è in grado di effettuare dei microtagli e di rendere più teneri pezzi di carne fresca senza rovinarli, arrivando a rompere fibre e nervature. Struttura robusta in acciaio inox 304, trasmissione ad ingranaggio, coltelli in acciaio facilmente asportabili.

 Designed for a professional use, the tenderizer is indispensable for any butcher shop and restaurant kitchen. Thanks to its tenderizing blades and micro-cuts, it can make the meat tender without ruining it, cutting off muscle fibres and sinews. Heavy-duty 304 s/steel construction; gear driven transmission, steel knives easy to remove.

 Machine à usage professionnel, indispensable dans toutes boucheries, restaurants et grandes cuisines. Avec son system de petits couteaux et micro-coupes, il arrive à attendrir la viande sans la ruiner, en coupant les fibres et les nerfs. Construction en acier inox 304, transmission par pignon, couteaux en acier faciles à démonter.

 Professionelle Gerätschaft, die in den Metzgereien, Restaurants und großen Küchen benutzt wird. Dank einem System von einschneidenden Messern kann sie Mikroschnitte durchführen, frische Fleischstücke zarter machen, ohne sie zu beschädigen, und Fasern und Nerven reißen. Robuste Struktur aus Edelstahl 304, Rädergetriebe, Messer aus Edelstahl, einfach zu entfernen.

 Instrumento profesional usado en las carnicerías, restaurantes y grandes cocinas que gracias a un sistema de cuchillas incisivas permite efectuar microcortes y convertir trozos de carne fresca en mas tiernos y sin arruinarlos, llegando a romper fibras y nervaduras. Estructura robusta en acero inoxidable 304, transmisión a engranajes, cuchillas de acero facilmente extraibles.

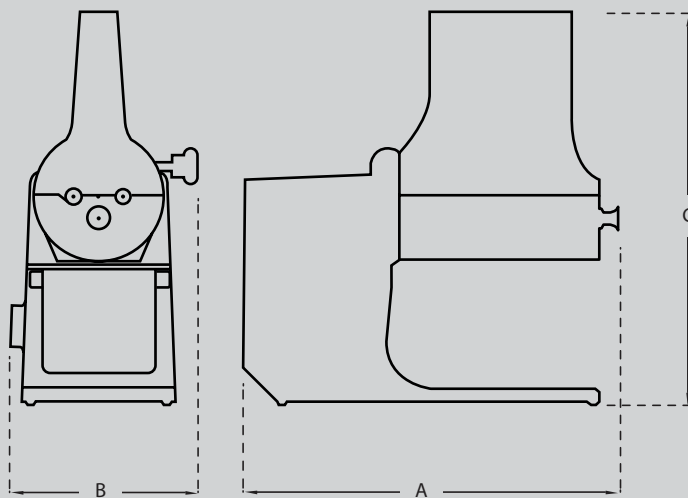

INTENERITRICE

INTENERITRICE

A **LARGHEZZA**
Width / Largeur
Breite / Ancho

A 440 mm

B **LUNGHEZZA**
Length / Longueur
Länge / Largo

B 170 mm

C **ALTEZZA**
Height / Hauteur
Höhe / Altura

C 480 mm

LAMA

Blade / Lame / Messer / Cuchilla

2x64 mm

CAPACITÀ DI TAGLIO

Cutting capacity / Capacité de coupe
Schneidleistung / Capacidad de corte

150x20 mm

POTENZA

Power / Puissance / Spannung / Potencia

0,15 kw

PESO NETTO

Weight / Poids / Gewicht / Peso

20 kg

DIMENSIONI IMBALLO

Packing dimensions / Dimensions emballage
Ausmas der Verpackung / Dimensiones embalaje

300x500x500 mm