

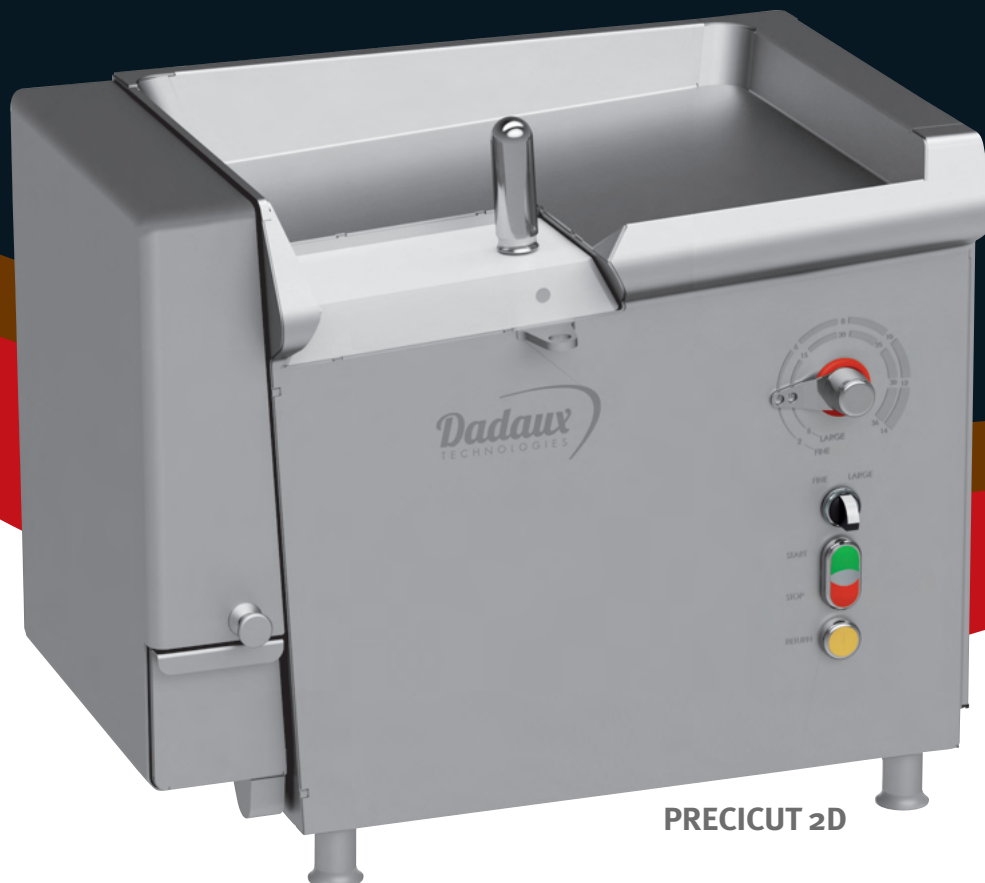

Cubeuse

PRÉCICUT 2D / 3D

L'évolution dans la découpe
Cutting improvement



PRECICUT 2D

Elaboration de divers produits
Découpe sous de multiples formes
Épaisseur de coupe réglable

*Elaboration of various product
Cutting numeros shapes
Adjustable cutting thickness*

Dadaux
TECHNOLOGIES

PRECICUT 2D

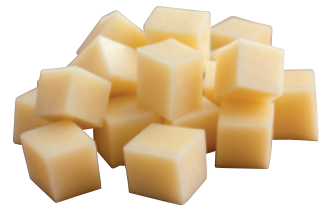

Outillage pour émincé, tartare, poisson, légume

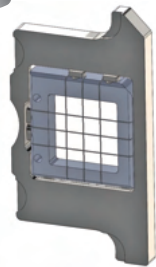

Fil pour fromage



Râpe

OUTILLAGES STANDARDS : 8 et 24 mm

OUTILLAGES AVEC LAMES DISPONIBLES Available tools ÉMINCÉS / TARTARE

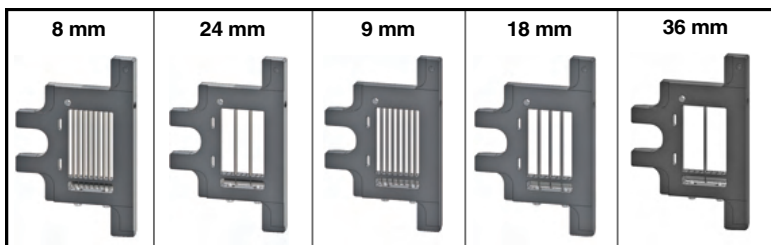

Pour tout outillage spécifique, merci de nous consulter.

ACCESSOIRES POUR RÂPE DE LÉGUME ET DE FROMAGE

Grater for cheese and vegetables
"Shredded disc"

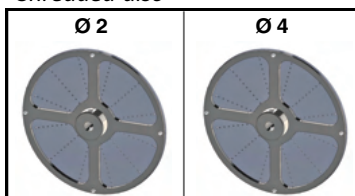

OUTILLAGE FIL

Tool for cheesedicing

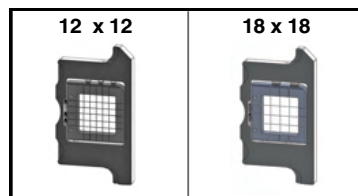

- Machine de table.
- Pour la production de cubes, émincés, lamelles, tartare aux couteaux, giros, shawarma, légumes...
- Entièrement INOX 18-10.
- Capacité 72 x 72 x 200 mm (environ 1 kg).
- Débit moyen 2 Kg/min.
- Livrée avec 1 outillage au choix.
- Fabrication française.
- Conforme aux normes C.E.
- Nettoyage haute pression (IP67).

Meat mincer type PRECICUT

- Table machine.
- For cubes, minced meat, strips, Tartar with knife, giros, shawarma, vegetables...
- Entirely stainless steel.
- Storage capacity : 72 x 72 x 200 mm (About 1 kg).
- Average output : 2 Kg/min.
- Delivered with 1 tool at choice.
- CE norms. Made in France.
- Cleaning high pressure.



Option :
Porte-goulotte
2D et 3D
Option : Chute door

PRECICUT 3D

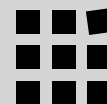

- Machine de table.
- Pour la production de cubes, émincés, lamelles, tartare aux couteaux, giros, shawarma, légumes...
- Entièrement INOX 18-10.
- Capacité 72 x 72 x 200 mm (environ 1 kg).
- Débit moyen 2 Kg/min.
- Livrée avec 1 outillage au choix.
- Fabrication française.
- Conforme aux normes C.E.
- Nettoyage haute pression (IP67).

Meat mincer type PRECICUT

- Table machine.
- For cubes, minced meat, strips, Tartar with knife, giros, shawarma, vegetables...
- Entirely stainless steel.
- Storage capacity : 72 x 72 x 200 mm (About 1 kg).
- Average output : 2 Kg/min.
- Delivered with 1 tool at choice.
- CE norms. Made in France.
- Cleaning high pressure.

CHOIX DE L'OUTILLAGE Tool choice

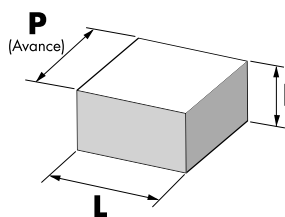

- H** : Espace en couteaux horizontal
Horizontal space between blades
- L** : Espace en couteaux vertical
Vertical space between blades
- P** : Avance réglée sur la machine
Adjusted advance on the machine

Le petit côté doit être fait par l'avance - The shorter side must be done with the advance.

OUTILLAGES STANDARDS : 8x8 et 24x24 mm

OUTILLAGES Available tools

En stock - In stock		Sur demande - On request		
8 x 8 mm	24 x 24 mm	9 x 9 mm	18 x 18 mm	36 x 36 mm

Pour tout outillage spécifique, merci de nous consulter.

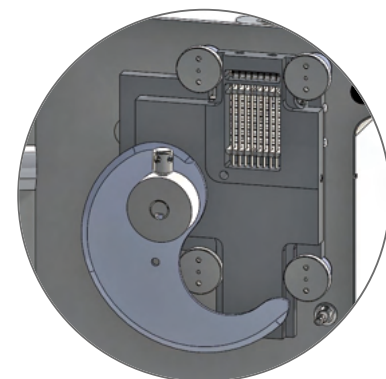

Détail de coupe
Cutting detail

CARACTÉRISTIQUES MACHINES *Machines characteristics*

Réf Ref	Tension Tension	Puissances Power	Avance Advance	Avance réglable Adjustable Advance	Vitesse couteaux Blade speed	Poids net Weight
PRECICUT 2D	Monophasé 230 V	Puissance couteaux : 0,55 kw Puissance avance : 0,18 kw <i>Knives power : 0,55 kw Advances power : 0,18 kw</i>	Electrique	1 à 40 mm	57 et 150 tr/min	66 Kg
PRECICUT 3D	TRI 400 V	Puissance couteaux : 0,75 kw Puissance avance : 0,55 kw <i>Knives power : 0,75 kw Advances power : 0,55 kw</i>	Hydraulique	1 à 60 mm	145 tr/min	122.5 Kg

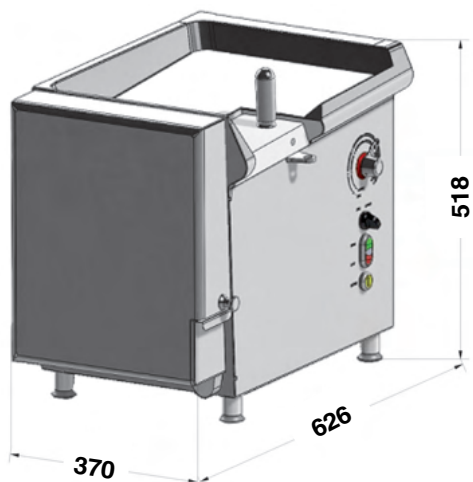

Dimensions
PRECICUT 2D

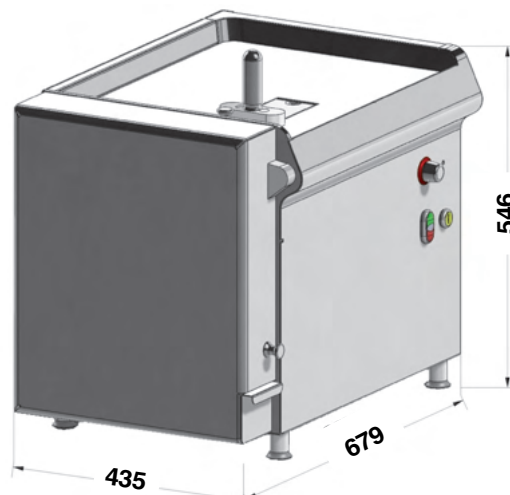

Dimensions
PRECICUT 3D



Qualité
100%
INOX

