

CUBEUSE

DICER MACHINE

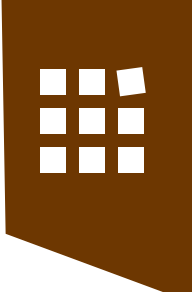



Precicut 1D



Precicut 2D

PRECICUT 1D / 2D / 3D

Machines de table

2D : production de cubes, émincés, lamelles, giros, shawarma, Kebab...

1D : tranchage de petites pièces de viande

Entièrement INOX 18-10

Capacité 72x72x200 mm (environ 1 kg)

Débit moyen 2 Kg/min

Livrée avec 1 outillage au choix

Fabrication française

Conforme aux normes C.E.

Table machine

2D : production of cubes, minced meat, strips, giros, shawarma, Kebab...

1D : slicing small pieces of meat

Entirely stainless steel

Capacities 72x72x200 mm (Approximately 1 kg)

Average flow 2 Kg/min

Delivered with 1 tool to the choice

French manufacturing

Conforms to the E.C. standards

Dimensions

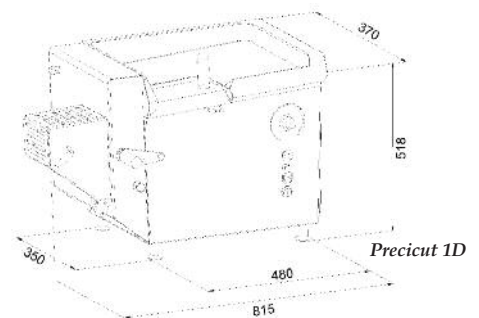

Precicut 1D

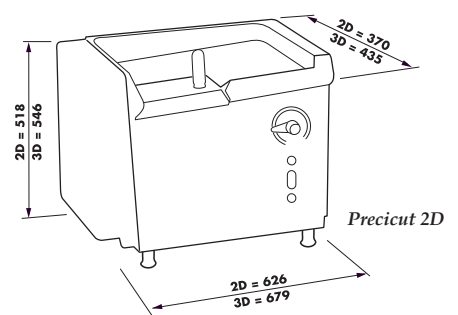

Precicut 2D



Outil de coupe
Cutting tool

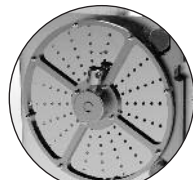

Option : Outil de coupe pour cubes de fromage
Option : Extra tool "Dicing attachments for cheese"

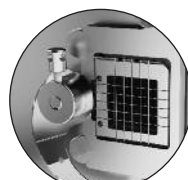

Option : Outil de coupe pour râpés de fromage & légume.
Option : Extra tool "Shredded disc"

Options disponibles

Available Options :

Outil de coupe pour cubes de fromage. /

Extra tools Dicing attachments for cheese.

Outil de coupe pour râpés de fromage & légume. /

Extra tool "Shredded disc".

Réf Ref	Tension Tension	Puissances Power	Avance Advance	Avance réglable Adjustable Advance	Vitesse couteaux Blade speed	Poids net Weight
PRECICUT 2D PRECICUT 1D	Monophasé 230V	Puissance couteaux : 0,55 kw Puissance avance : 0,18 kw Knives power : 0,55 kw Advances power: 0,18 kw	Electrique	1 à 40 mm	2D : 57 et 150 tr/min 1D : 160 tr/min	66 Kg
PRECICUT 3D	TRI 400 V	Puissance couteaux : 0,75 kw Puissance avance : 0,55 kw Knives power : 0,75 kw Advances power: 0,55 kw	Hydraulique	1 à 60 mm	145 tr/min	122.5 Kg